

Borg Warner (Schwitzer) S4D / S4DW Type Turbos

Common Repair Parts
Oversize Repair Parts

S4D Type

Component Parts Common

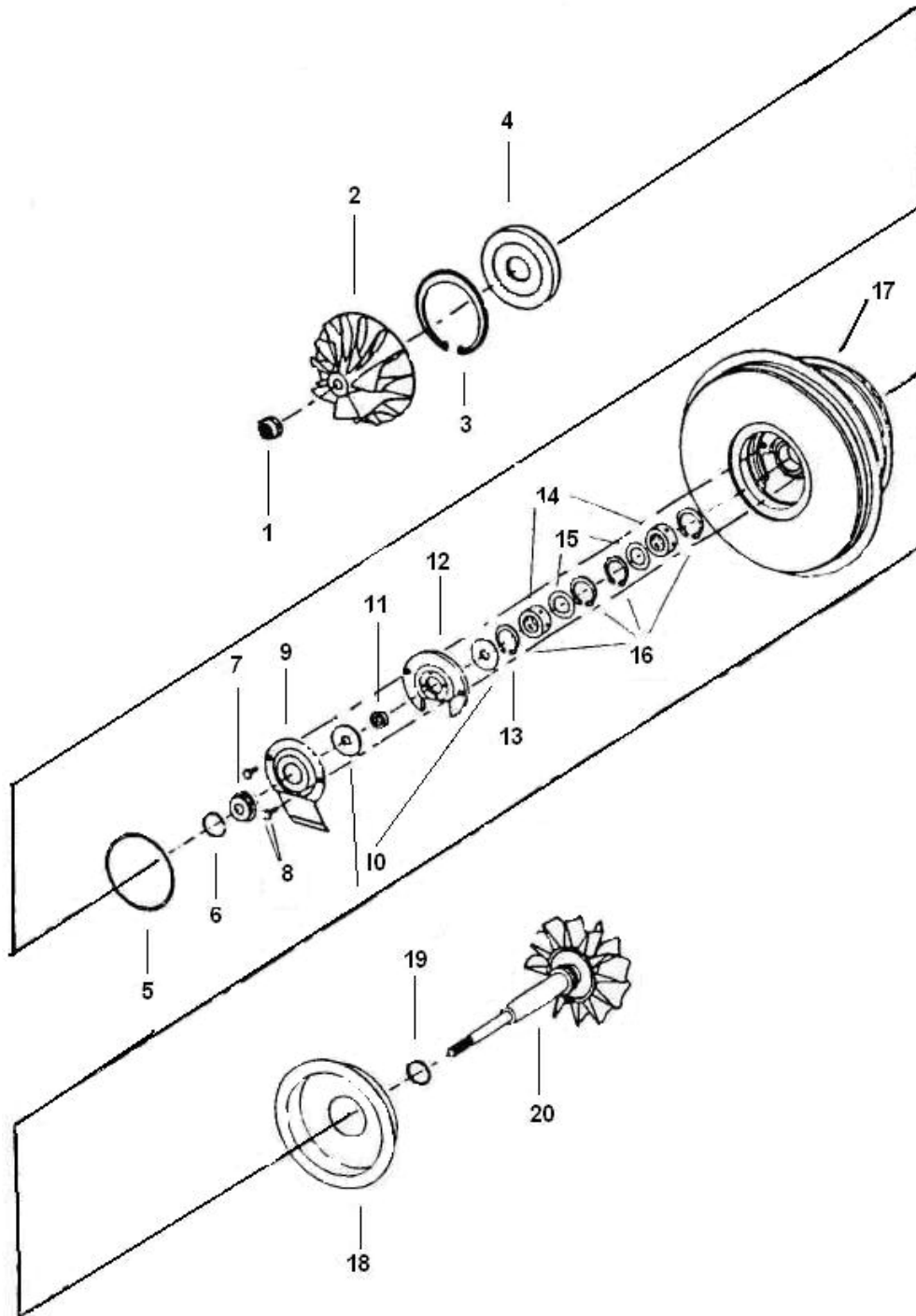

S4D Type

Repair Parts & Service Kits

All parts are available for purchase as individual components or in the following popular Repair Kits

Key	Part Description	MELETT Part Number	Qty Per Turbo	Repair Kit
14	Journal Bearing (Std/Std)	1252-419-100	2	See Note below Repair kits in development
16	Retaining ring (J-brg)	1100-180-140	4	
5	O Ring (Insert)	1250-030-150	1	
19	Piston Ring (Turb)	1252-419-160	1	
6	Piston Ring (Comp)	1150-400-170	2	
10	Thrust Ring	1301-036-240	2	
1	Shaft Nut	1250-040-350	1	
	Locknut (V-Band)	1100-120-645	2	

These models are currently under development in 2007 – please contact Melett Sales for latest availability.

Parts shown on this page are available from stock.

Oversize Repair Parts Available

Journal Bearings		
Original Schwitzer Part Number (Std/Std): 188985		
Oversize's Available		Part Number
OD +.010"	ID -.010"	1252-419-120
OD +.010"	ID Std	1252-419-124
OD Std.	ID -.010"	1252-419-127
OD +.020"	ID Std	1252-419-137

Piston Ring – Turbine End			Piston Ring – Compressor End		
Original Schwitzer Part Number (Turb End): 194798			Original Schwitzer Part Number (Comp End): 310724		
Oversize's Available		Part Number	Oversize's Available		Part Number
OD +0.010"	Wth Std	1252-419-161	OD +.020	Wth Std	1150-400-180
OD +0.020	Wth Std	1252-419-162	OD +.010	OD +.010	1150-400-185
OD Std	Wth +0.010"	1252-419-181			

Borg Warner (Schwitzer) S4T Type Turbos

Common Repair Parts
Oversize Repair Parts

S4T Type

Component Parts Common

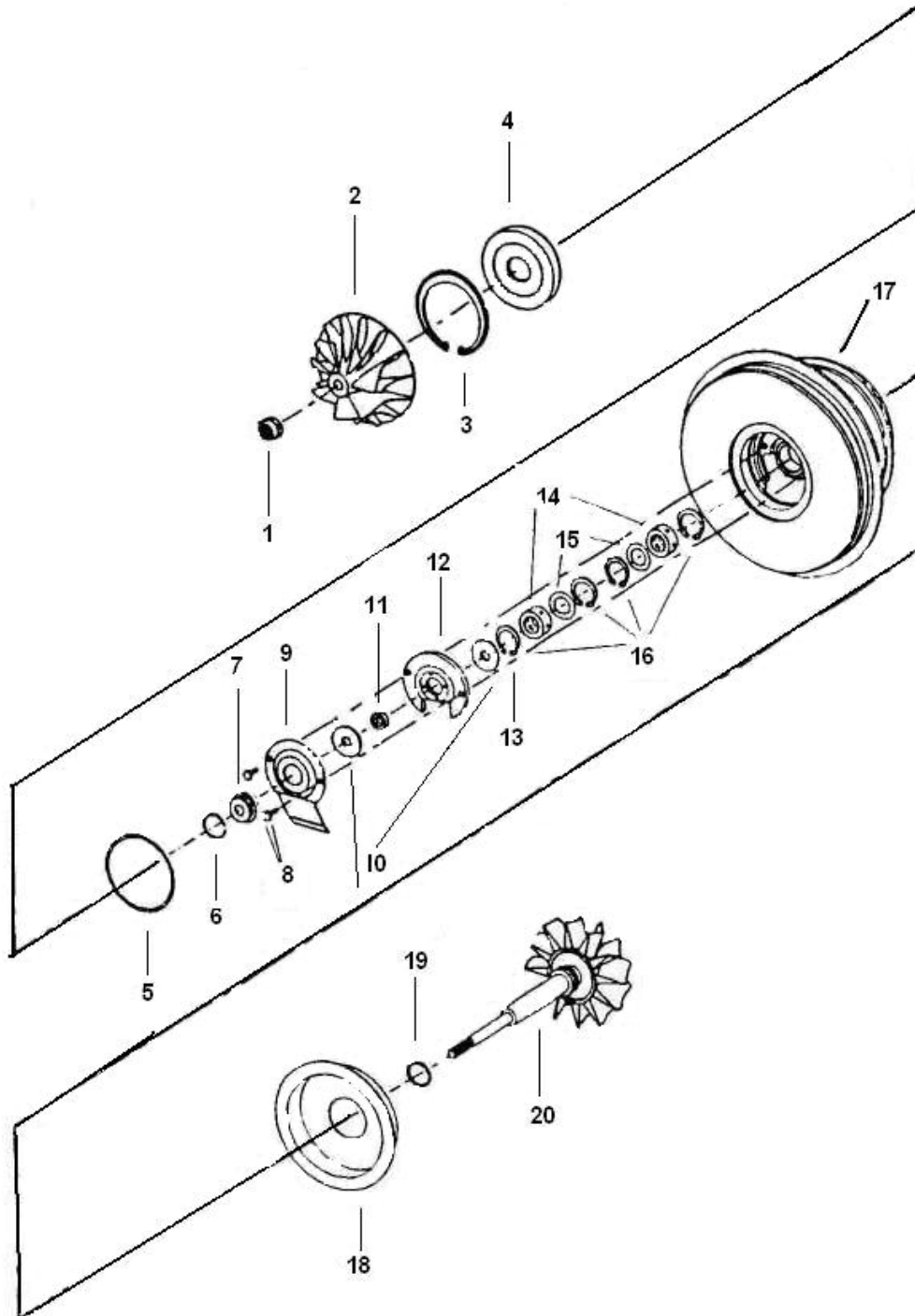

S4T Type

Repair Parts & Service Kits

All parts are available for purchase as individual components or in the following popular Repair Kits

Key	Part Description	MELETT Part Number	Qty Per Turbo	Repair Kit
14	Journal Bearing (Std/Std) (189483)	N/A	2	See Note below Repair kits in development
14	Journal Bearing (Std/Std) (139055)	1252-004-100	2	
16	Retaining ring (J-brg)	1250-404-140	4	
5	O Ring (Insert)	1250-030-150	1	
19	Piston Ring (Turb)	1252-419-160	1	
6	Piston Ring (Comp)	1150-400-170	2	
10	Thrust Ring	1301-036-240	2	
	Oil Control Sleeve	1250-404-260	1	
12	Thrust Bearing (188585)	N/A	1	
12	Thrust Bearing (313407)	N/A	1	
1	Shaft Nut	1250-040-350	1	
	Locknut (V-Band)	1100-120-645	2	

These models are currently under development in 2007 – please contact Melett Sales for latest availability.

Parts shown on this page are available from stock.

Oversize Repair Parts Available

Oversize bearings not currently available		

Piston Ring – Turbine End Original Schwitzer Part Number (Turb End): 194798			Piston Ring – Compressor End Original Schwitzer Part Number (Comp End): 310724		
Oversize's Available		Part Number	Oversize's Available		Part Number
OD +0.010"	Wth Std	1252-419-161	OD +.020	Wth Std	1150-400-180
OD +0.020	Wth Std	1252-419-162	OD +.010	OD +.010	1150-400-185
OD Std	Wth +0.010"	1252-419-181			